

GRB mixers®



in

instrucciones termostático

thermostatic instructions

instructions thermostatique

GRB mixers®

Alaún 19, Pla-Za

50197 Zaragoza (Spain)

www.grbmixers.com · info@grb.es

048700.99



GRB is a Spanish Certified Product. CEE



Aspectos generales

Installation and assembly · Installation et montage

Primero, purgar las tuberías

First, drain pipes

Tout d'abord, purger la tuyauterie

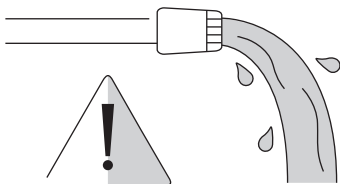

ALTURA DE INSTALACIÓN RECOMENDADA RECOMMENDED INSTALLATION HEIGHT HAUTEUR D'INSTALLATION RECOMMANDÉE

termostático horizontal
horizontal thermostatic
thermostatique horizontal

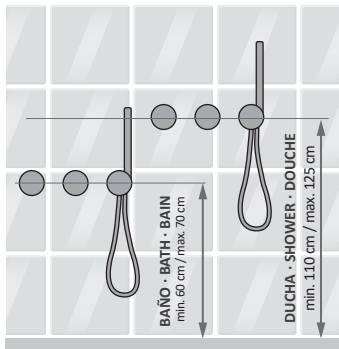

termostático vertical
vertical thermostatic
thermostatique vertical

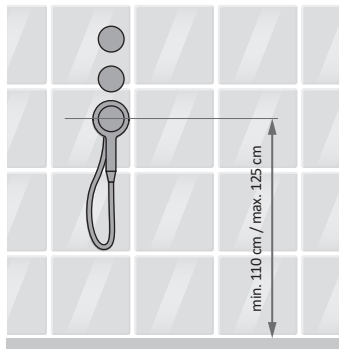



Instalación y montaje

Installation and assembly · Installation et montage

termostático horizontal

horizontal thermostatic · thermostatique horizontal

90 004 000 / 90 005 000

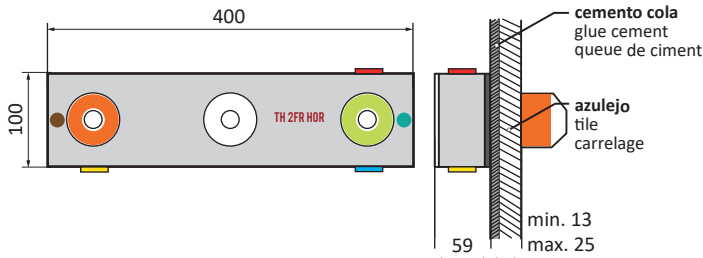

termostático vertical

vertical thermostatic · thermostatique vertical

90 006 000 / 90 007 000 / 90 008 000 / 90 009 000

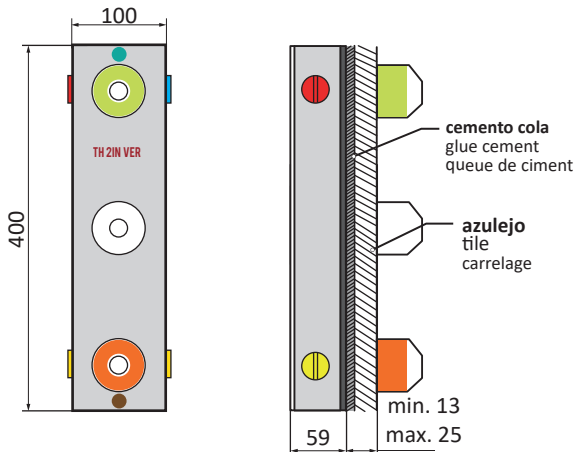

1 Dimensiones · Dimensions · Mesures

termostático horizontal
horizontal thermostatic
thermostatique horizontal

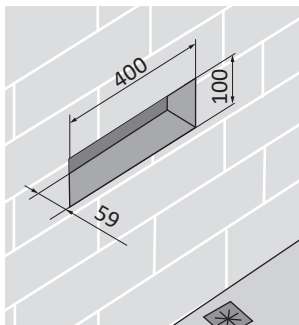

termostático vertical
vertical thermostatic
thermostatique vertical

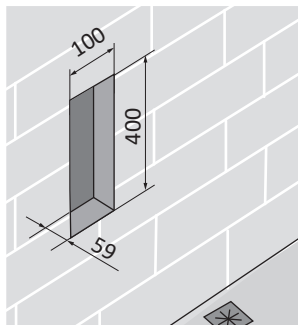

- 2 Retire el cartón protector y lea las instrucciones** · Remove protective carton and read the instructions · Retirez le carton de protection et lisez les instructions

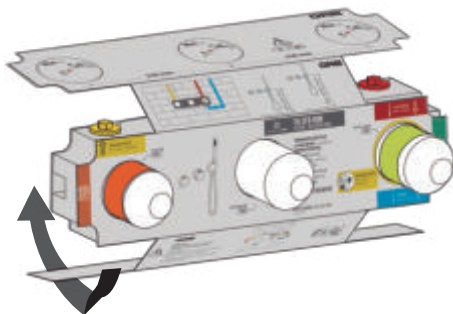

3 Posición · Position · Position

termostático horizontal · horizontal thermostatic · thermostatique horizontale

TH 2FR HOR

90 004 000

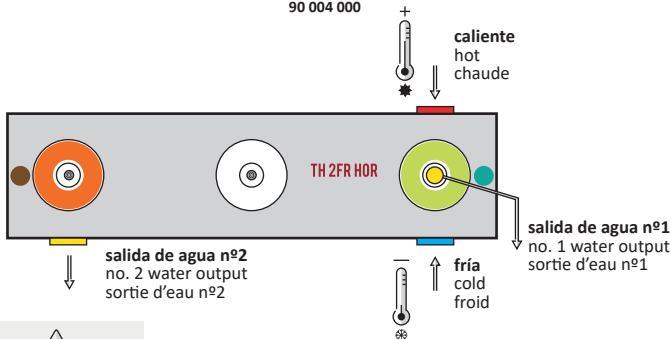

ATENCIÓN: no emplear las salidas selladas.
ATTENTION: do not use blocked outputs.
ATTENTION: ne pas utiliser les voies bloquées.

TH 3FR HOR

90 005 000

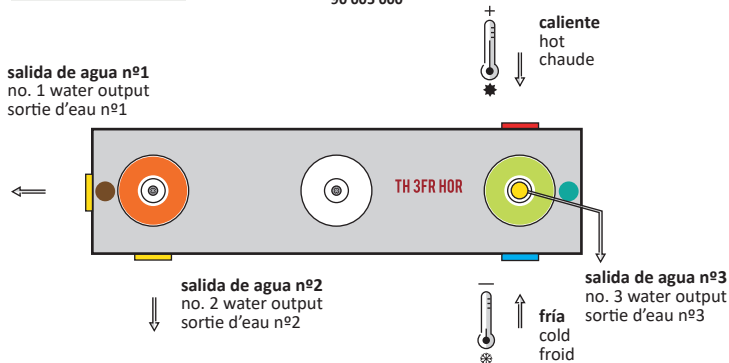

termostático vertical
vertical thermostatic · thermostatique vertical

TH 2FR VER
90 006 000

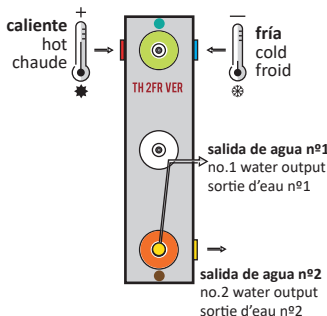

TH 3FR VER
90 007 000

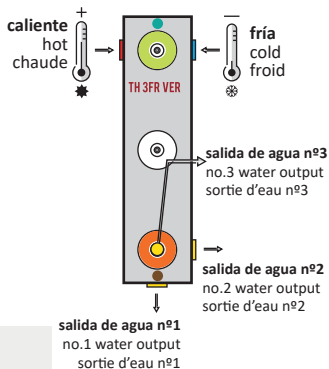

ATENCIÓN: no emplear las salidas selladas.
ATTENTION: do not use blocked outlets.
ATTENTION: ne pas utiliser les voies bloquées.

TH 2IN VER
90 008 000

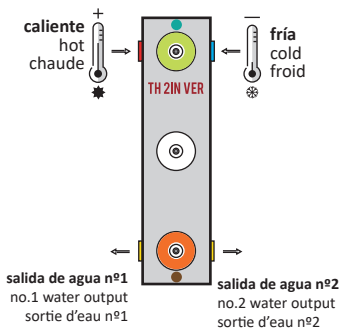

TH 3IN VER
90 009 000

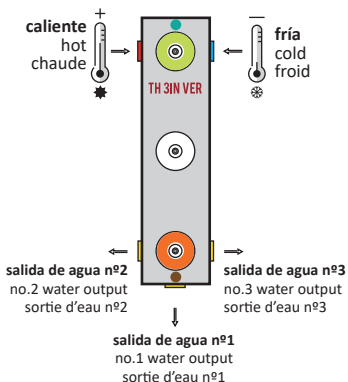

4 Nivelar · Level · Nivelez

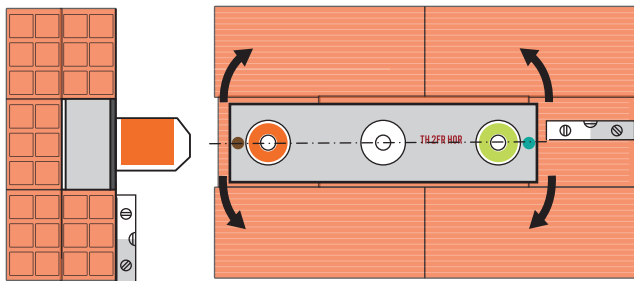

5 Alicatar · Shape · Carrez

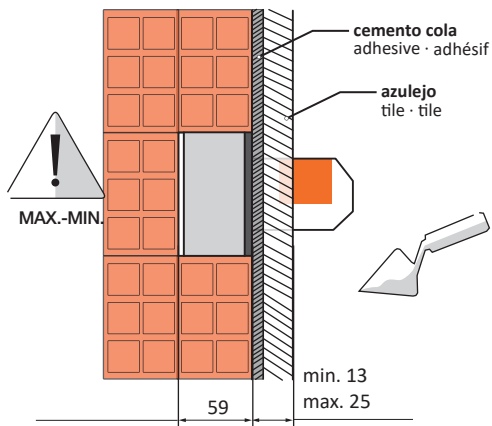

7 Marcar el azulejo y taladrar con corona · Mark the tile with drill · Marquer la tuile avec le perceuse

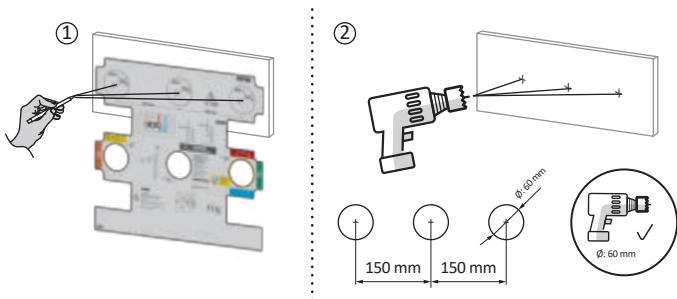

8 Colocar el azulejo en la pared · Place the tile on the wall · Placez le tuile sur le mur

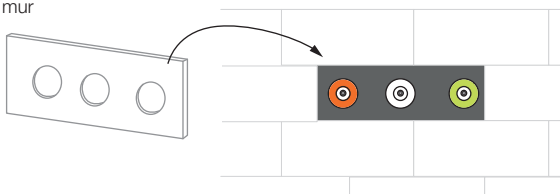

9 Retirar la protección · Remove the foam · Retirez la protection

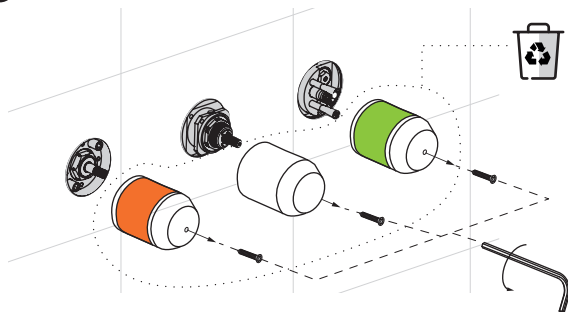

9 Colocación final · Final position · Placement final

1. Maneta desviador

Diverter handle
Manette déviateur

2. Maneta temperatura

Temperature handle
Manette temperature

3. Tapa filtros

Filters cover
Couvercle filtres

TH 2FR HOR / TH 3FR HOR
90 004 000 / 90 005 000

TH 2IN VER / TH 3IN VER
90 008 000 / 90 009 000

TH 2FR VER / TH 3FR VER
90 006 000 / 90 007 000

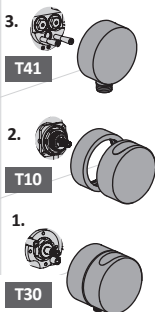
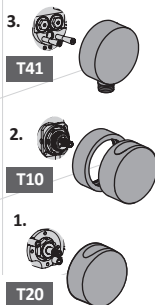
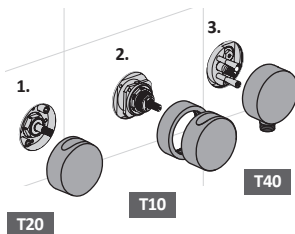

¡ATENCIÓN! · ATTENTION

Las instrucciones de colocación de cada elemento, las encontrará en su correspondiente caja.

You will find inside the correspondent box the installation instructions of each element.

Les instructions de placement de chaque élément, vous les trouverez dans le boîte correspondante.



Posibles incidencias en la instalación

Possible incidents during the installation

Incidents possibles pendant l'installation

INCIDENCIA / INCIDENT CAUSAS POSIBLES / POSSIBLE CAUSES SOLUCIÓN / SOLUTION

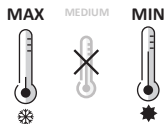

Temperatura intermedia no disponible.
Intermediate temperature not available.
Température intermédiaire non disponible.

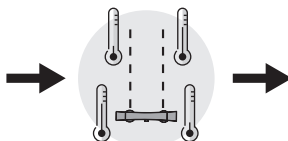

El agua caliente y fría están invertidas.
The hot and cold water are reversed.
L'eau froide et l'eau chaude sont inversées.



Invierta las tuberías o seleccione un producto especial GRB.
Reverse the pipes or select a special GRB product.
Inversez les tuyaux ou sélectionnez un produit spécial GRB.

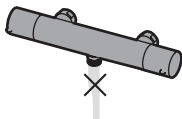

No sale agua.
No water flow.
L'eau ne coule pas.



Una de las alimentaciones está cortada.
One of the supplies is cutted.
Une des alimentations est fermée.



Revise la instalación.
Check the installation.
Vérifiez l'installation.

Tras un cambio o mantenimiento de la caldera, se recomienda purgar las tuberías y limpiar los filtros antes de utilizar cualquier grifería.

After a change or maintenance of the boiler, it's recommended to drain the pipes and to clean the filters before using any taps.

Après un changement ou réparation de la chaudière, il est recommandé de purger les tuyaux et de nettoyer les filtres avant d'utiliser un robinet.

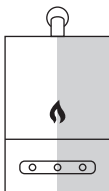

purgar las tuberías
drain pipes
purger la tuyauterie

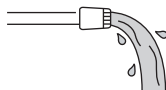



Instrucciones de uso

instructions for use · instructions d'utilisation

2 salidas 2 ways · 2 voies

POSICIONES DESVIADOR
DIVERTER POSITIONS · POSITIONS DÉVIATEUR

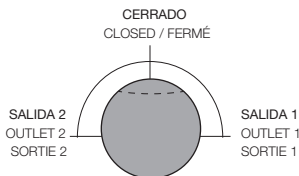

TEMPERATURA
TEMPERATURE

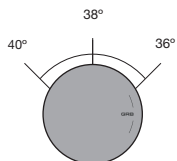

3 salidas 3 ways · 3 voies

POSICIONES DESVIADOR
DIVERTER POSITIONS · POSITIONS DÉVIATEUR

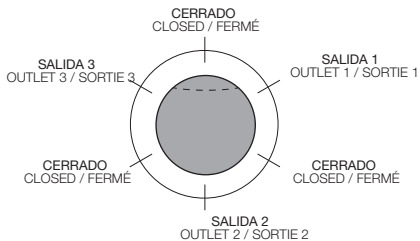

TEMPERATURA
TEMPERATURE

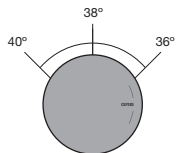



Acceso a mecanismos

Access to mechanisms / Accès aux mécanismes

Cerrar el agua. · Close the water. · Fermer l'eau.

1_A

Retirar la maneta
Take the handle.
Retirez la manette.

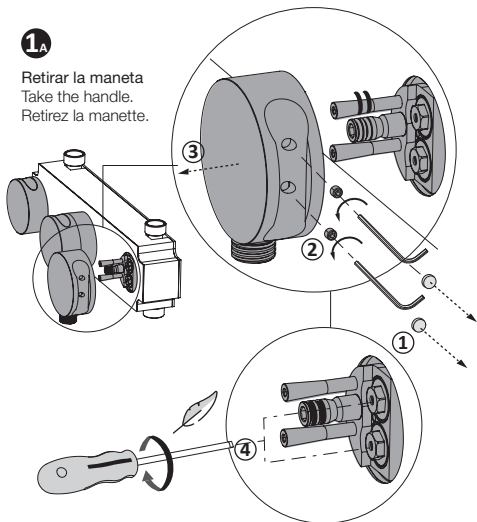

1_B



2

Acceder.
To access.
Accès

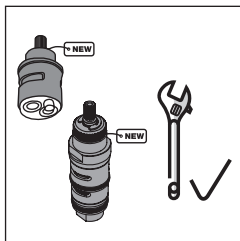
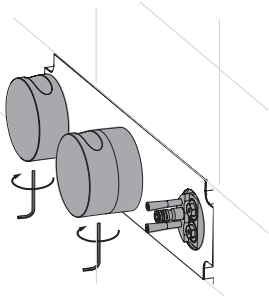

Limpeza de filtros. Clean filters. Nettoyage des filtres.

1

Cerrar el agua.
Close the water.
Fermer l'eau.



2

Retirar el mango y flexo
Remove handshower and hose.
Retirez la douchette et la flexible.

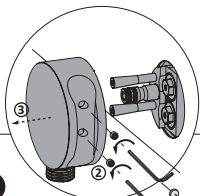
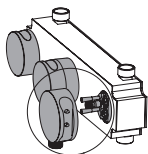
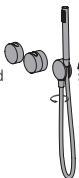

3

Retirar la tapa.
Remove the cap.
Retirez la couverture.

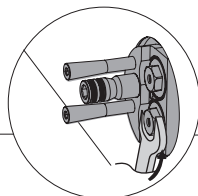

4

Aflojar la válvula
Loosen up the valve.
Desserrer la bonde.

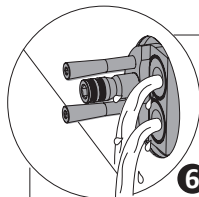

6

Purgar cuerpo/grifería.
Drain the tap.
Purger la robinetterie.

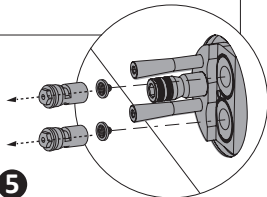

5

Sacar los filtros, limpiarlos o sustituirlos.
Take teh filters clean them or replace.
Retirez les filtres, nettoyer ou replacer.

7

Introducir los filtros en la misma posición
Place the filters in the same position.
Placer des filtres dans la même position.



Limpieza y mantenimiento

Maintenance and cleaning · Nettoyage et maintenance



Clorhidric acid



Formic acid



Acetic acid

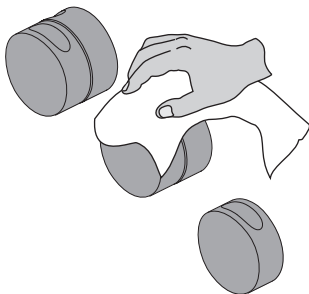
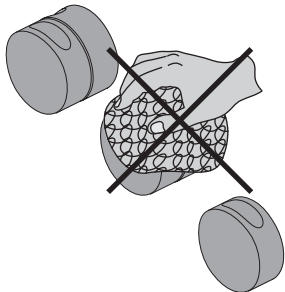
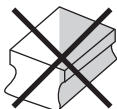

WARRANTY 5 YEARS

GARANTIE 5 ANS

To guarantee the quality of its products, Griferías Grober, S.L. -GRB-, has established rigorous controls in its manufacturing processes. Processes and products are audited by external entities of the highest prestige to maintain a high degree of its products' quality.

GRB offers a **5-year** warranty on its products from the date of installation.

There is a limitation of the Warranty to **2 years** for :

- Batteries for items with electronic systems and their electrovalves.
- Hoses, showerheads and handshower, fixed or sliding supports.
- Valves
- Exterior finishes rosé, gold, brushed gold, wood, and walnut wood
- Any specification or special adaptation to a client or user, unless otherwise agreed.
- Discontinued products, from their discontinuation date.

This guarantee covers all the products of the catalog against material and manufacturing defects and will be applicable provided that the use and installation have been in accordance with the instructions for use.

In all cases, acceptance by the GRB Technical Department is necessary to give validity to this guarantee.

The extension of information and application of this guarantee can be found on: grb.es/servicio-postventa/

Pour garantir la qualité de ses produits, Griferías Grober, S.L. -GRB-, a mis en place des contrôles rigoureux dans ses processus de fabrication. Les processus et les produits sont audités par des organisations externes de prestige afin de maintenir un haut niveau d'exigence de qualité.

GRB offre une garantie de **5 ans** sur ses produits à partir de la date d'installation.

La garantie est limitée à **2 ans** pour :

- Batteries des articles dotés de systèmes électroniques et leurs électrovannes.
- Flexibles de douche, pommes de douche et poignées, supports fixes ou coulissants.
- Vidages
- Finitions extérieures en rosé, or, or brossé, bois et bois nogal.
- Toute spécification ou adaptation spéciale à un client ou à un utilisateur, sauf accord contraire.
- Produits étants hors catalogue, depuis sa date de retrait.

Cette garantie couvre tous les produits du catalogue contre les défauts de matériaux et de fabrication et s'applique à condition que l'utilisation et l'installation aient été conformes aux instructions d'utilisation.

Dans tous les cas, l'acceptation par le département technique de GRB est nécessaire pour que cette garantie soit valable.

De plus amples informations et l'application de cette garantie sont disponibles sur : grb.es/servicio-postventa/

GRB mixers®



GRBmixers[®]

GARANTÍA 5 AÑOS

Para garantizar la calidad de sus productos, Griferías Grober, S.L. -GRB-, tiene establecidos rigurosos controles en sus procesos de fabricación. Procesos y productos son auditados por entidades externas de máximo prestigio con el fin de mantener un alto grado de exigencia en la calidad de los mismos.

GRB ofrece una garantía de sus productos de **5 años** desde la fecha de instalación.

Existe una limitación de la Garantía a **2 años** para:

- Baterías de los artículos con sistemas electrónicos y sus electroválvulas
- Flexos, rociadores y mangos de ducha, soportes fijos o deslizantes.
- Valvulería
- Acabados exteriores en rosé, oro, oro cepillado, madera y madera nogal
- Cualquier especificación o adaptación especial a un cliente usuario, salvo acuerdo contrario
- Productos descatalogados, desde su fecha de descatalogación.

Esta garantía cubre todos los productos del catálogo contra defectos de materiales y de fabricación y será aplicable siempre que la utilización e instalación, hayan sido conforme a las instrucciones de uso. En cualquier caso, es necesario la aceptación por el Departamento Técnico de GRB para dar validez a esta garantía.

La ampliación de información y aplicación de esta garantía la puede encontrar en: grb.es/servicio-postventa.

nº

fecha · date · date

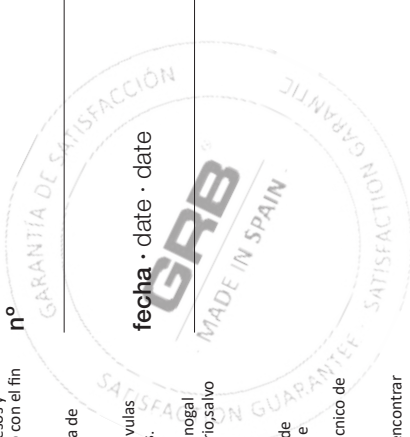

sello del distribuidor · stamp of distributor · cachet du distributeur

GRB is a Spanish Certified Product CEE