

4

5

5

6

7

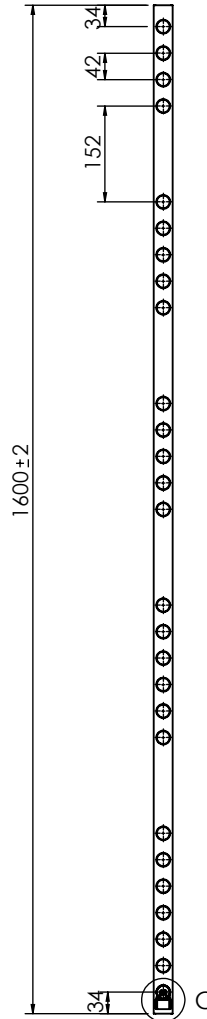

KESİT A-A
ÖLÇEK 1 : 12

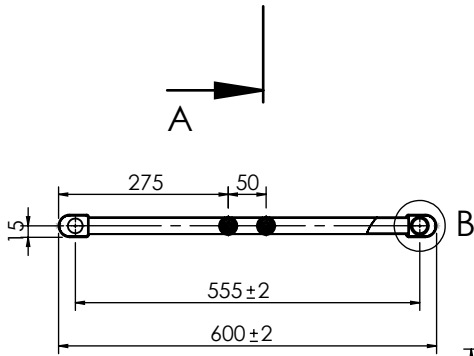

DETAY B
ÖLÇEK 1 : 2

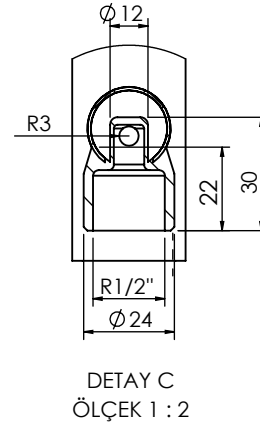
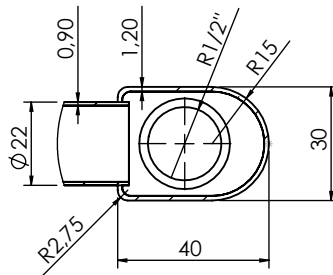

DETAY C
ÖLÇEK 1 : 2

AKSİ BELİRTİLMEDİĞİ SÜRECE:
BOYUTLAR MİLMETREDİR
YÜZEY CİLASI:
TOLERANSLAR:
DOĞRUSAL:
AÇISAL:

BİTİRME:

KESKİN KENARLARI
PAHLAYIN VE
KIRIN

TEKNİK RESMİ ÖLÇEKLENDİRMEYİN

REVİZYON

İSİM	İMZA	TARİH
ÇİZEN SERKAN DEMİR		
DENET.		
ONAY.		
ÜRET.		
KALİTE		
MALZEME:		
AĞIRLIK:		

BAŞLIK:
600X1600 DÜZ ORTA BAĞLANTILI 27 boru
n=(4+5+5+6+7)

RESİM NO.

A3

ÖLÇEK:1:20

SAYFA 1 / 1